

# GREASE

## MTPT250 - GREASE SEPARATOR DATASHEET

ABOVE OR BELOW GROUND INSTALLATION

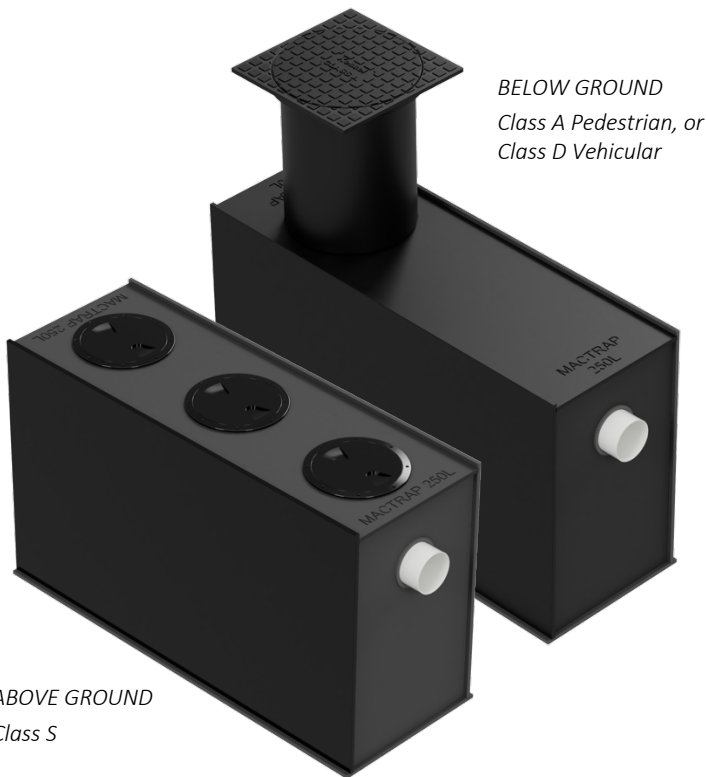

*BELOW GROUND  
Class A Pedestrian, or  
Class D Vehicular*

*ABOVE GROUND  
Class S*

Product code	MTPT250S	MTPT250A/D
Total Volume	392 l	392 l
Treatment Capacity	250 l	250 l
Grease Containment	63 l	63 l
Length	1200 mm	1200 mm
Width	520 mm	520 mm
Height	628 mm	1078 <sup>1</sup> mm
Inlet invert	450 mm	450 mm
Outlet invert	400 mm	400 mm

<sup>1</sup> Includes height of riser

### Accessories

Class A or D sampling chamber	MTIC350A/D
-------------------------------	------------

## OPERATION

Mactrap grease separation systems intercept fats, oils, and grease (FOG) collected in wastewater from sources such as kitchens, bakeries, and food processing plants. These grease separators are amongst the lightest weight and most durable FOG capture systems available.

Wastewater enters the separator and the heavier food sediment sink to the bottom of the chamber while at the same time the FOG rises to the surface. Cleaned wastewater exits the separator without allowing any of the separated sediment or FOG to leave the separating chambers.

## WARRANTY

The Mactrap grease separator is warranted for impermeability, fitness for use and structural stability for thirty (30) years when installed underground and ten (10) years when installed above ground. The manufactured unit is warranted for quality of manufacture for five (5) years provided the separator is installed and operated in accordance with the specifications provided with each unit. Mactrap warranty does not include maintenance and servicing of the separator.





## AFTER-INSTALLATION CARE AND SERVICING

Whilst this product is highly robust, care is required to ensure efficient operation.

### Water temperature

The separator is certified to operate with water temperatures up to 65°C. Higher continuous temperatures may cause sagging when installed above ground.

### Chemicals

The separator is tested to handle most kitchen factory type chemicals especially as they are usually diluted with water. Pure benzene and concentrated sulphuric acid should not be used.

### Sink Filters



Loading the separator up with food waste will increase the frequency of clean outs along with the associated cost. The more food waste pre-removed using sink filters, the higher the efficiency of the separator and the lower the cost of operation.

### Clean Out

The frequency of clean out is totally dependent on how much FOG and food sediment is intercepted. Most separators are sized for a three-monthly cleanout, however heavy usage may require more frequent clean outs. In normal circumstances separator are cleaned out by a vacuum truck. The entire contents are drained and removed before refilling the separator for continued operation.

## COVERS AND RISERS

- Mactrap grease traps are available with pedestrian strength (Class A) and vehicular strength (Class D) covers.
- Riser height is inherently flexible between 220mm and 450mm. Extensions are available.
- Flexible coupling allows easy installation into the surrounding medium.
- Fully sealed for odour protection.
- Surrounding concrete or other medium must be engineered.

Type	Class	Typical Use	Nominal Wheel Loading (kg)	Serviceability Design Load (kN)	Ultimate Limit State Design (kN)
	A	Areas accessible strictly by pedestrians. Not suited to vehicles. Purpose – residential backyards, walkways not accessible by vehicles.	330kg	6.7kN	10kN
	D	Major roads including freeway and motorway shoulders. Warehouse and loading docks. Purpose – major roads.	8,000kg	160kN	240kN

