

FUEL/OIL SEPARATOR

MTFO2000 – DATASHEET

Above or below ground installation



PROTECTING THE ENVIRONMENT

Mactrap Oil and Grit Interceptors are chosen nationwide for their robust and lightweight construction, ease of installation and 30 year in-ground warranty. They separate and trap light oils and grit in areas such as vehicle wash downs, truck stops, garages and service stations. Mactrap Oil and Grit Interceptors are used wherever wastewater can be contaminated by light oils and surface sludge and grit.

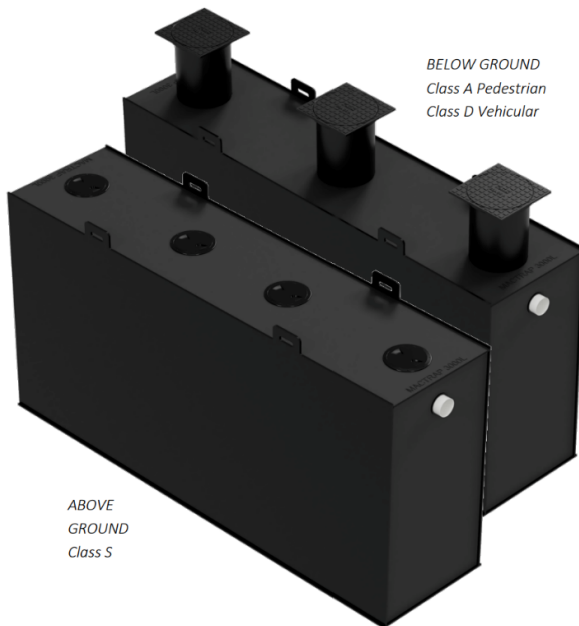

Product code	MTPT2000S	MTPT2000 A/D includes risers
Flow Rate	9 l/s	9 l/s
Treatment Capacity	1997 l	1997 l
Length	2820mm	2820mm
Width	800mm	800mm
Height	1210mm	1660mm
Weight	240kg	255/300kg
Inlet invert	955mm	955mm
Outlet invert	885mm	885mm
Connections	150mm	
Class A or D sampling chamber	MTIC350A/D	

COVERED WASH BAYS

Mactrap Oil and Grit Interceptors are highly effective at trapping and storing oil and grit in compliance with Local Authority Bylaws. Wastewater enters the interceptor, and the light oil rise to the surface while heavier sludge and grit sinks to the bottom of the chamber. Separated wastewater flows out of the interceptor while the oil and grit remain trapped and stored within the interceptor.

UNCOVERED WASH BAYS

Mactrap Stormwater Diversion with Oil & Grit Interceptor System is recommended when the hydraulic load comes from both wash down activity and rain events. This systems is designed for exposed wash bays where stormwater cannot enter the wastewater network, and the stormwater network must be protected from contaminants. Call Mactrap for more information.





WASH BAYS WHERE SPILLS MAY OCCUR

Mactrap API Interceptors are required where there is risk of spills requiring containment. Call Mactrap information.

EMULSIFIED OIL AND CONTAINMENT

Mactrap Oil & Grit Interceptors are built “ready” for the addition of advanced options that insure against oil entering the wastewater network (self-closure lock) and aiding in separation of the oil droplets that have been emulsified (coalescing filter).

Coalescence Filter

Option: A coalescence filter captures small droplets of oil that are too small to separate in water by gravity alone. The small droplets combine (coalesce) into larger droplets which will separate and be trapped.

Self-Actuated Closure Lock

Option: A self-activated closure lock completely closes the outlet of the interceptor when the interceptor reaches its maximum fuel/oil storage volume, preventing the escape of fuel/oils to the drainage system.

Alarm Units

Option: To reduce the chances of the separator shutting down due to overcapacity in the fuel/oil storage chamber, an alarm unit can be installed which monitors the fuel/oil level. *Mactrap recommends the installation of these alarm units in high fuel oil applications.*



MAINTENANCE



The frequency of clean out is dependent on how much fuel oil is intercepted and stored. Your Trade Waste consent will advise a maximum interval between extractions.

WARRANTY

The Mactrap Oil and Grit Interceptor is warranted for impermeability, fitness for use and structural stability for thirty (30) years when installed underground and ten (10) years when installed above ground. The manufactured unit is warranted for quality of manufacture for five (5) years provided the separator is installed and operated in accordance with the specifications provided with each unit. Mactrap warranty does not include maintenance and servicing of the separator.

COVERS AND RISERS

Pedestrian or vehicular strength cover with inherent height flexibility.



Type	Class	Typical Use	Nominal Wheel Loading (kg)	Serviceability Design Load (kN)	Ultimate Limit State Design (kN)
	A	Areas accessible by pedestrians	330kg	6.7kN	10kN
	D	Major roads including freeway and motorway shoulders. Warehouse and loading docks.	8,000kg	160kN	240kN





COVERS AND RISERS

- Installation options of pedestrian strength (Class A) and vehicular strength (Class D) covers.
- Standard riser height has inherent flexibility, and extensions are available for deeper installations
- Fully sealed for odour protection.
- The concrete or other medium surrounding the covers must be engineered.

Type	Class	Typical Use	Nominal Wheel Loading (kg)	Serviceability Design Load (kN)	Ultimate Limit State Design (kN)
	A	Areas accessible by pedestrians	330kg	6.7kN	10kN
	D	Major roads including freeway and motorway shoulders. Warehouse and loading docks.	8,000kg	160kN	240kN

Standard Risers – inherent adjustments

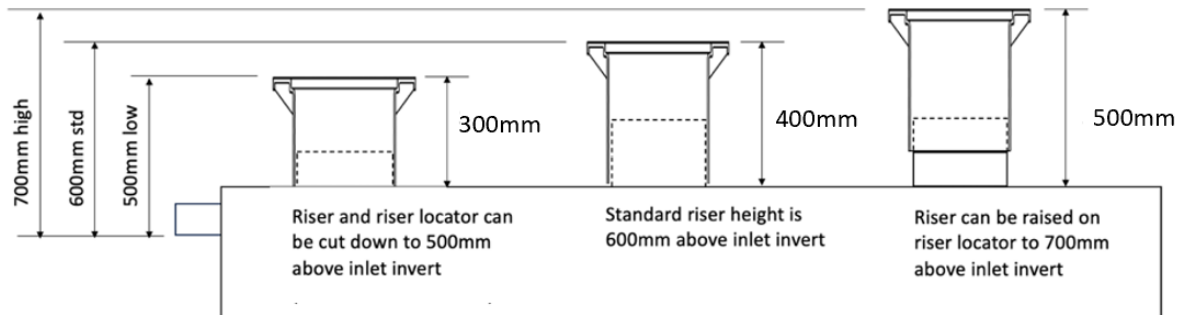

Riser extensions

Riser extensions are available where the trap must be installed deeper than the standard riser height.

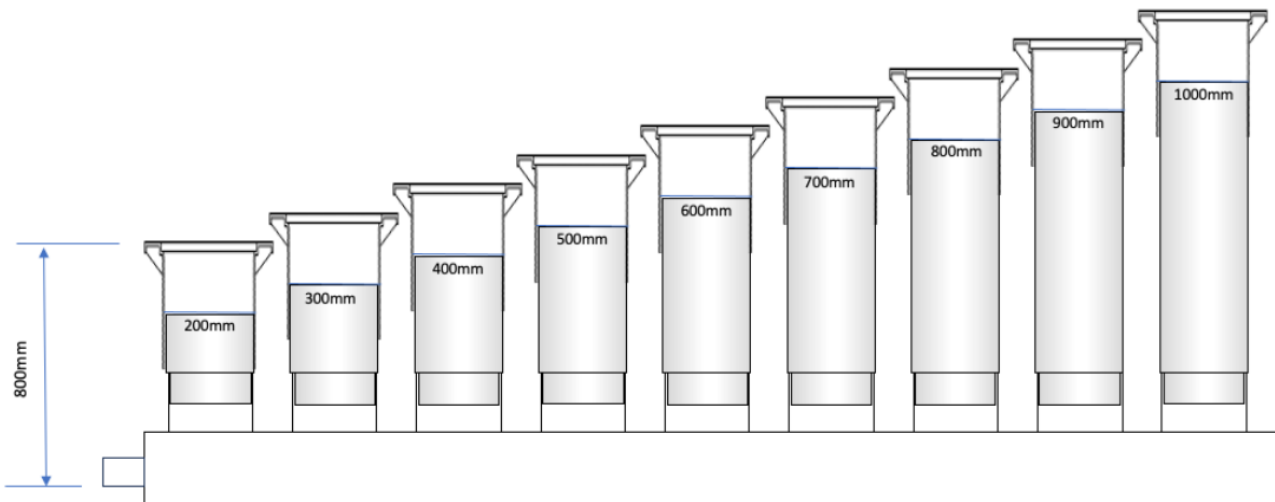

Installation depth of greater than 1 metre requires a static load bridge.

